



HUBER

Screw Press Q-PRESS®

- ▶ Sludge dewatering with efficient performance data
- ▶ Maximum operational safety
- ▶ Optimized operating and disposal costs

More information,
downloads and
current news



Sludge dewatering

Sludge conditioned with flocculant is pumped via a flocculation section directly into the cylindrical filter basket of the HUBER Screw Press Q-PRESS® wherein an auger rotates at a very slow speed. The geometry of the auger continuously reduces the volume in the filter basket so that free water is pressed out of the sludge.

The auger pushes the increasingly thicker sludge towards an annular clearance past a pneumatically adjustable pressure cone at the discharge end.

A scraper on the screw shaft permanently cleans the filter basket from inside due to the rotation of the shaft. A stationary spray bar backwashes the filter basket of the HUBER Screw Press Q-PRESS® periodically and segment by segment from the outside. The dewatering process is not interrupted from size 620.2.

Parameters used for adjustment and control include not only the sludge feed and flocculant dosing and admixing, but also the screw shaft speed, the sludge feeding pressure and the pneumatic counterpressure of the discharge cone.

Innovation

Energy efficiency:

The screw drives exceed the current energy efficiency standards of electric motors. Due to maximised electrical efficiency the HUBER Screw Press Q-PRESS® can therefore be operated with higher solids throughputs.

Dewatering results:

Specially developed scrapers on the screw shaft permanently and reliably clean the inner filter surface with every rotation of the screw. Free water can thus very easily run off. As a result, dewatering efficiency increases and flocculant consumption is reduced.

Due to the significantly enlarged open filter surface filter baskets with the same bar spacings are able to handle higher hydraulic loads without impairment of filtrate quality.

The outside of the filter is cleaned without interrupting the dewatering process. The predewatering and press zone can be washed independently of each other. Rewetting of press sludge through washing is reduced to a minimum especially in the press zone without neglecting the important washing in the predewatering zone.

Maintenance:

As an option, the three segments of the filter baskets are available as axially divided segments. Only the upper half of the basket needs to be removed for maintenance. The lower half of the filter basket can be removed from the screw shaft by means of a special mechanism but remains inside the filtrate chamber of the Q-PRESS® during maintenance. This saves a lot of time, reduces space requirements and the need for using lifting devices for maintenance.

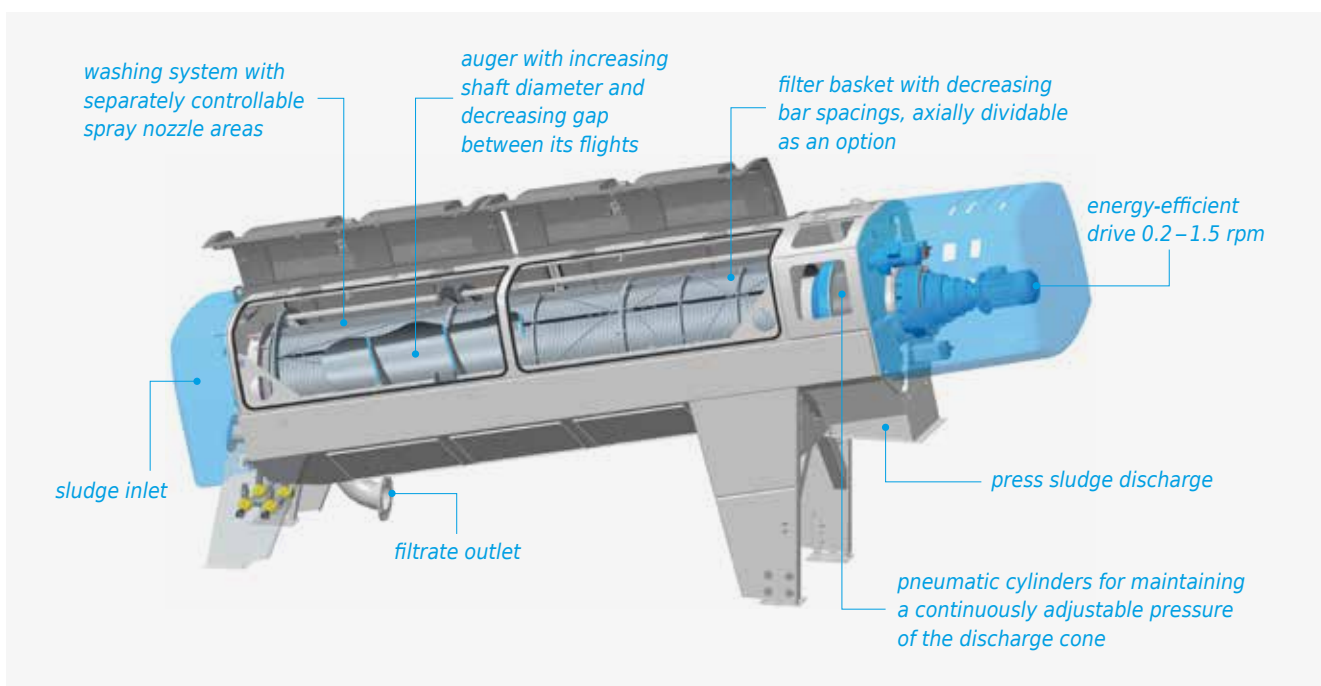

Partial section of a HUBER Screw Press Q-PRESS®.

Advantages

High dewatering

- ▶ defined sludge volume reduction in the screw press
- ▶ continuously adjustable counterpressure at the discharge end
- ▶ filtrate discharge enhanced by gravity due to inclined installation
- ▶ unique scraper system for permanent cleaning of the inner filter surface
- ▶ significantly increased free filter surface
- ▶ continuous dewatering

Reliable operation with little downtime

- ▶ virtually no wear because of < 1 rpm screw rotation speed
- ▶ sturdy stainless steel design
- ▶ dividable filter baskets available as an option
- ▶ simplified filter dividing mechanism
- ▶ easy access through large inspection openings
- ▶ minimal space requirements for maintenance
- ▶ simple self-monitoring control strategy
- ▶ proven in thousands of installations



Stationary mounted Q-PRESS® 440.2 for 3 m³/h.

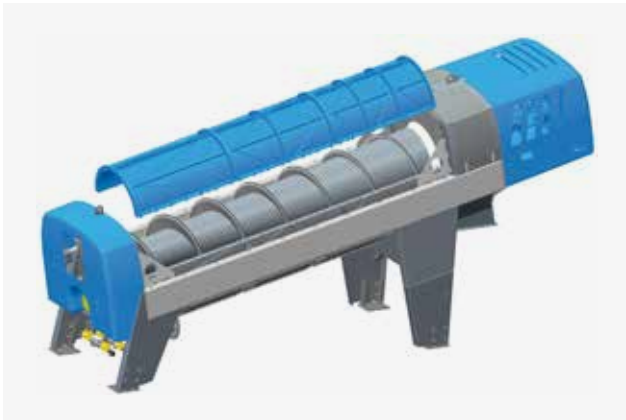

HUBER Screw Press Q-PRESS® inclined installation with optionally dividable screen baskets.

Minimum operation costs

- ▶ outstanding energy efficiency
- ▶ specific power consumption < 8 kWh/t_{DR}
- ▶ little operator attention (< 20 min/day)
- ▶ high solids capture rate > 97%

Low total investment costs

- ▶ compact design and small footprint
- ▶ easy connection of the screw conveyor
- ▶ optional tube flocculator
- ▶ integrated support legs
- ▶ vibration-free, virtually noiseless operation
- ▶ fully enclosed design
- ▶ optional extraction of air



Sturdy wedge wire basket made of stainless steel.



Digested sludge dewatering up to 30% DR.

Special applications of the Q-PRESS®

Dewatering of thin sludges

Due to pump feeding, large volumes of sludge water are removed already in the pre-dewatering zone. This permits cost-efficient dewatering of thin sludges with a solids concentration < 1%.

Benefits

- ▶ sludge dewatering without the need for prior thickening
- ▶ typical dewatering results of 18 – 25% DS
- ▶ sludge volume reduction up to > 97% in a single step
- ▶ saves investment and operation costs for preceding sludge thickening
- ▶ little operator attention required

Variable sludge characteristics

Dewatering performance is usually impaired and operator attention increased by frequently varying sludge quality. Our HUBER Screw Press Q-PRESS® automatically self-adjusts to over- and underloading. A control loop makes sure that optimal operation is always maintained.

Benefits

- ▶ always optimum performance
- ▶ flexible with varying sludge qualities
- ▶ minimised operator attention
- ▶ reliable operation



Q-PRESS® 620.2 for surplus sludge dewatering.



HUBER Screw Press Q-PRESS® 800.2 for 20 m³/h.

Unit sizes / performance

Size	Throughput [kg _{DR} /h]	Drive [kW]	Weight [t]
280	15 – 90	0.55	0.7
440.2	30 – 180	1.5	1.5
620.2	60 – 350	2.3	2.7
800.2	90 – 540	3.1	3.5



The sizes of the HUBER Screw Press Q-PRESS®.

HUBER SE

Industriepark Erasbach A1 | 92334 Berching
Phone: +49 8462201-0 | info@huber.de
www.huber.de

HUBER Screw Press Q-PRESS®

Subject to technical modification | 0,1 / 12 – 3.2022 – 7.2010