

HUBER

Screenings Wash Press WAP/HP



Screenings Wash Press with
automatically controlled high-pressure unit

- Dewatering performance up to 60 % DR
- Weight reduction up to 80 %
- Increase of the thermal value of screenings

►► Design and function

Minimize the water content of screenings with high pressure!

The screenings to be treated are discharged directly from a screen or conveyor (e.g. screw conveyor) into the feed trough of the Wash Press. A robust conveying and compacting screw transports the screenings into the wash zone where they are exposed to directed and powerful turbulence created by automatic introduction of wash water (service water). The turbulence achieves perfect separation of organic particles and thus effective screenings washing. The washing intensity and cycles are individually adjustable. The washed screenings are further conveyed in the rising pipe to the press zone where they are intensively pre-pressed by the compacting screw. In the following second press zone the screenings are compacted and dewatered under high pressure to a DS content of up to 60 %. Especially wear-resistant and solid materials in the conical high-pressure unit ensure reliable long-term operation of the plant. The press water from screenings compaction is collected under the high-pressure unit and discharged along with the wash water which is rich in carbon. Automatic cleaning with water of the wear collecting tank under the machine and the complete high-pressure unit is possible. The washed and compacted screenings are finally transported through the conical discharge pipe into a skip.



Reliable screenings dewatering with the WAP/HP

►► The user's benefits

- Dewatering performance up to 60 % DR
- Volume, weight and disposal cost reduction by up to 80 %
- Hydraulically controlled high-pressure zone
- Completely made of stainless steel (including the compacting screw)
- Return of carbon-rich filtrate to wastewater stream
- Insensitive to coarse material
- Screened wastewater or process water can be used as wash water
- Sturdy design
- Compacting screw with reinforced flights for wear protection
- High economic efficiency due to reduced transport and disposal costs

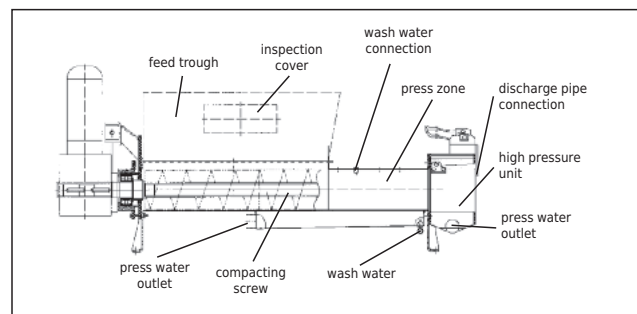

The hydraulic high-pressure unit guarantees a high DR.

HUBER SE

Industriepark Erasbach A1 · D-92334 Berching
 Phone: + 49 - 84 62 - 201 - 0 · Fax: + 49 - 84 62 - 201 - 810
 info@huber.de · Internet: www.huber.de

Subject to technical modification
 1,5 / 4 – 7.2010 – 4.2005

HUBER Waschpresse WAP/HP